

Received 10/1/89

Los Alamos National Laboratory is operated by the University of California for the United States Department of Energy under contract W-7405-ENG-36

LA-UR--89-2137

DE89 014220

TITLE DISK GENERATOR WITH NEARLY SHOCKLESS ACCELERATED DRIVER PLATE

AUTHOR(S) C. M. FOWLER
R. F. HOEBERLING
S. P. MARSH

SUBMITTED TO FIFTH INTERNATIONAL CONFERENCE ON MEGAGAUSS MAGNETIC FIELD
GENERATION AND RELATED TOPICS
JULY 3-7, 1989
NOVOSIBIRSK, USSR

DISCLAIMER

This report was prepared as an account of work sponsored by an agency of the United States Government. Neither the United States Government nor any agency thereof, nor any of their employees, makes any warranty, express or implied, or assumes any legal liability or responsibility for the accuracy, completeness, or usefulness of any information, apparatus, product, or process disclosed, or represents that its use would not infringe privately owned rights. Reference herein to any specific commercial product, process, or service by trade name, trademark, manufacturer, or otherwise does not necessarily constitute or imply its endorsement, recommendation, or favoring by the United States Government or any agency thereof. The views and opinions of authors expressed herein do not necessarily state or reflect those of the United States Government or any agency thereof.

In acceptance of this article, the publisher recognizes that the U.S. Government retains a nonexclusive, royalty-free license to publish or reproduce the published form of this contribution, or to allow others to do so, for U.S. Government purposes.

This article is published at the publisher's expense. The publisher identifies this article as work performed under the auspices of the U.S. Department of Energy.



Los Alamos Los Alamos National Laboratory
Los Alamos, New Mexico 87545

MASTER

DISTRIBUTION STATEMENT 1

14

DISK GENERATOR WITH NEARLY SHOCKLESS ACCELERATED DRIVER PLATE*

C. M. Fowler, R. F. Hoerberling, and S. P. Marsh

Los Alamos National Laboratory,
Los Alamos, New Mexico, USA 87545

I. INTRODUCTION

The "disk" generator, shown schematically in Fig. 1, was first conceived here as a useful magnetic field source for a class of in situ plasma experiments.¹ Initial current is supplied (from a capacitor bank) to the generator through radial coaxial cables. It enters the top plate, passes through the central post, and exits through the top of the outer cylindrical glide surface, which is insulated from the top plate. The explosive over the top plate is initiated simultaneously over its upper surface at such a time that the top plate starts its downward motion at about peak initial current. Generators of this class were first developed by Chernyshev, Protasov, and Shevtsov² who called them "disk" generators, the name we have adopted here.

Several conditions were required for the experiments under consideration: the top or driver plate should contact the bottom plate nearly parallel to it; the generator interior should be evacuated; microjetting debris (fluff) arising from the driver plate should be held to a minimum; currents developed should be several tens of megamperes, with values of di/dt exceeding 10^{13} A/s.

Results from three shots are reported. In the first two nearly identical shots, the explosive was placed in contact with the driver plate. In the third experiment, the explosive was placed parallel to the driver plate but above it with a stand-off distance of 12.7 mm. The stand-off volume was also evacuated.

As noted by Asay,³ microjetting is greatly reduced when the driver plate is accelerated gently, and its front surface is free of perturbations such as dents and scratches. Preferably, this surface should also be polished to a high finish, as was done here.

Design details of the generator are given in Sec. II. They are based in considerable part on two-dimensional hydrodynamic calculations. Shot results are summarized in Sec. III, together with a discussion of the data obtained.

* This work was supported by the US Department of Defense.

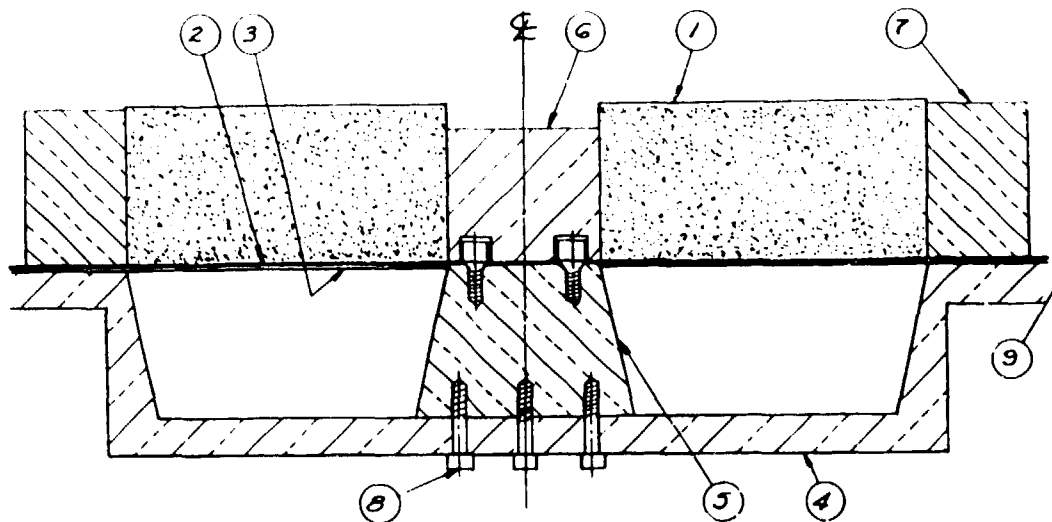

Fig. 1. Disk generator details: 1) explosive ring, 263.5-mm OD, 50.8-mm ID, 50.8-mm high. Other generator dimensions drawn to scale; 2) driver plate, 1.6-mm-thick copper; 3) insulation, 0.7-mm thick; 4) bottom plate and cylindrical glide surface, copper, one piece; 5) central post, tantalum or copper; 6) top explosive support piece, tantalum or copper; 7) explosive support ring, brass; 8) screws, four at top of post, five at bottom; 9) plates extended for radial cable connections with appropriate clamps and O-rings.

II. GENERATOR DESIGN DETAILS

A number of the generator design details were determined, in part, by two-dimensional hydrodynamic calculations. Figure 2a shows the components adapted in the final design for the first two shots, in which the explosive was in direct contact with the driver plate. Figure 2b shows the calculated position of the driver plate just before it reaches the bottom of the central post and outer cylindrical glide surface. (For simplicity, the bottom plate has been left out of the calculations.) For comparison, consider the corresponding results of Fig. 3b, for an earlier design attempt, Fig 3a. Addition of the heavy metal ring around the explosive and addition of copper to the outer generator glide cylinder eliminated the large lag of the driver plate at its outer radius. The poor driver plate contact at the central post was improved by putting an angle on the post and replacing the central cylinder of explosive by the cylindrical support piece.

Evacuation of the generator volume was achieved through a small port drilled through the bottom plate. The driver plate, when glued to the bottom surface of the explosive, showed no detectable displacement after the system was evacuated. A combination of O-rings with suitable clamps, together with judiciously applied silastic, proved sufficient to seal the insulated radial input slot.

The design for the third shot, in which the explosive was offset from the driver plate, was essentially unchanged in major detail. The supports for the explosive ring are shown schematically in Fig. 4a. Somewhat surprisingly, the calculations indicated that the explosive support structure was rather critical. The conical wedges shown, resulted in much better calculated plate motion than other support structures having less metal added to the supports. Evacuation of the standoff region was accompanied through a small radial port drilled through the brass ring surrounding the explosive. During evacuation, it proved important to maintain nearly equal pressures in both

the generator and stand-off volumes to avoid driver plate displacement. Making both volumes vacuum tight proved to be not as difficult as anticipated. Silastic beads effectively sealed the explosive ring to the inner and outer metal cylinders, while the addition of O-rings to the top surface of the input slot insulation completed the vacuum seal.

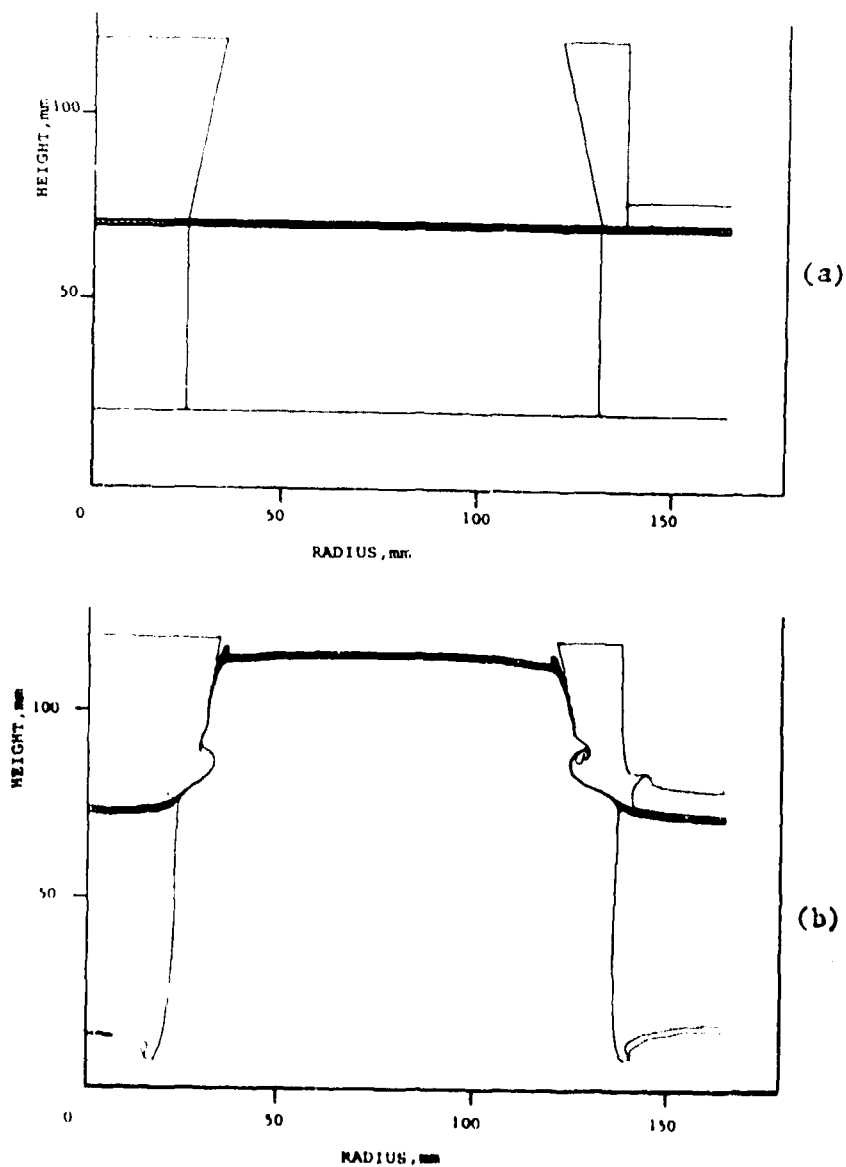

Fig. 2. (a) Initial setup showing key components used in hydrodynamic calculation for Fig. 1, the system finally adopted. Note that explosive is in contact with driver plate; (b) calculated result showing driver plate (shaded) near end of its run.

Figure 4b shows the calculated driver plate configuration near the end of its run. Somewhat surprisingly, its contact with the bottom plate appears at least as good or better than that of Fig. 2b.

Figure 5 shows the calculated positions of the front surfaces of the driver plates vs time from first motion. Values are plotted at a radius about half way between that of the post and the cylindrical glide surface. The curve on the left was calculated for

the case where the explosive is in contact with the driver plate. As expected, the plate takes off with the free surface velocity calculated for the explosive-copper configuration. Motion for the stand-off configuration was calculated in more detail for early times. As expected the initial shock on the driver plate was much reduced, with the consequence that the plate starts at greatly reduced velocity.

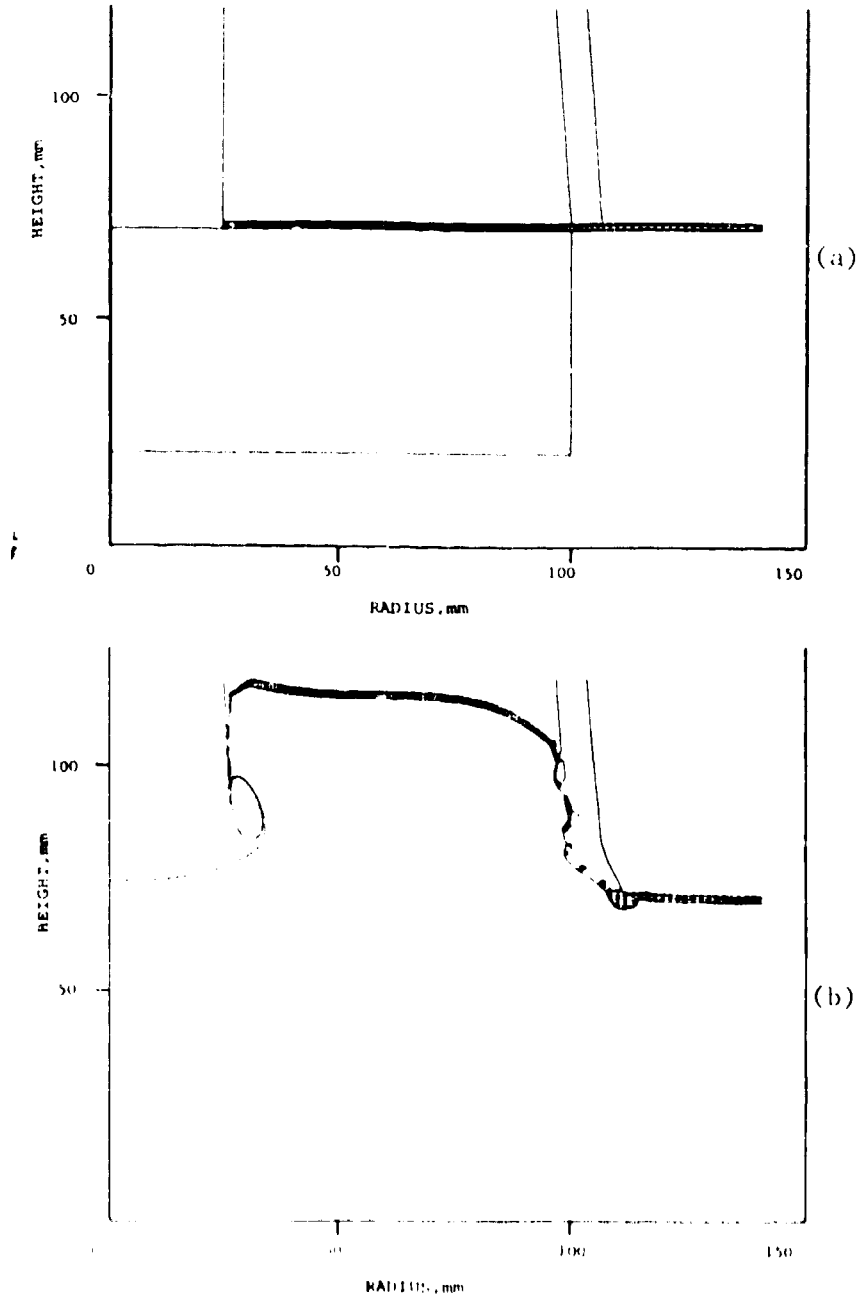

Fig. 3. (a) Initial setup for an earlier design study. Note the absence of the explosive retaining ring, and support plug, as well as the cylindrical instead of conical post; (b) the driver plate configuration, near the end of its run, is completely unsuitable.

The total plate run distance was 49.6 mm. (The initial separation of driver and bottom plates.) As seen from Fig. 5, calculated arrival times for the two cases differ by about a microsecond, 13.35 μ s for the case where the explosive and plate are in contact,

and $14.4 \mu\text{s}$ where there is stand off between the plate and explosive. Interestingly, the plate velocity at this distance of run is somewhat higher for the latter situation (4.17 vs $4.00 \text{ mm}/\mu\text{s}$).

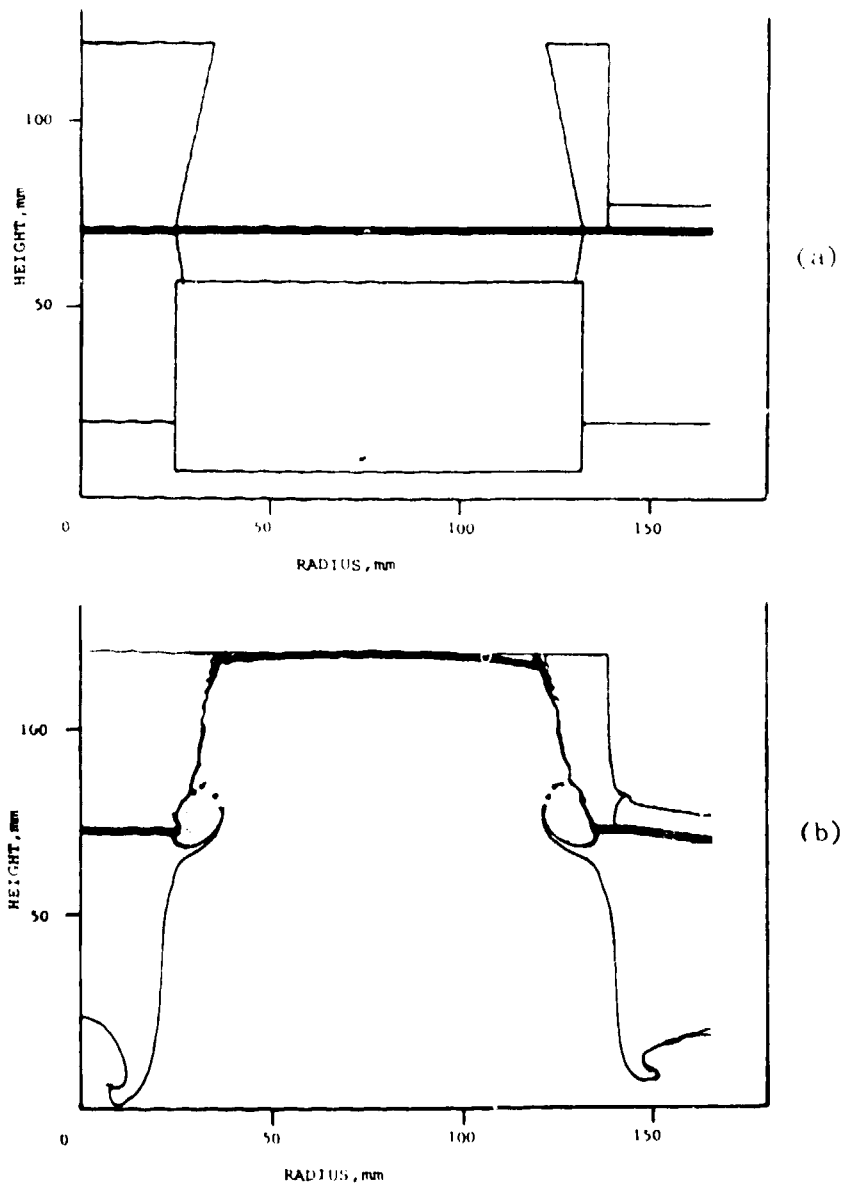

Fig. 4. (a) Initial setup adopted for the "stand-off" configuration, showing a 12.7-mm gap between driver plate and explosive; (b) the driver plate configuration near the end of its run is quite good.

III. SHOT RESULTS AND DISCUSSION

Current diagnostics consisted of a Rogowski loop around the output cables from the capacitor bank, and a Rogowski loop and B_θ probe placed in the bottom plate of the generator, as shown in Fig. 6. Both of these latter probes were recessed in the bottom plates to allow plate contact before probe destruction. Fears that the partial shielding of the B_θ probe might vary during the generator run proved groundless. The B_θ probe signals retained proportionality with both the internal Rogowski loop signal and with the capacitor bank Rogowski probe up to generator crowbar time.

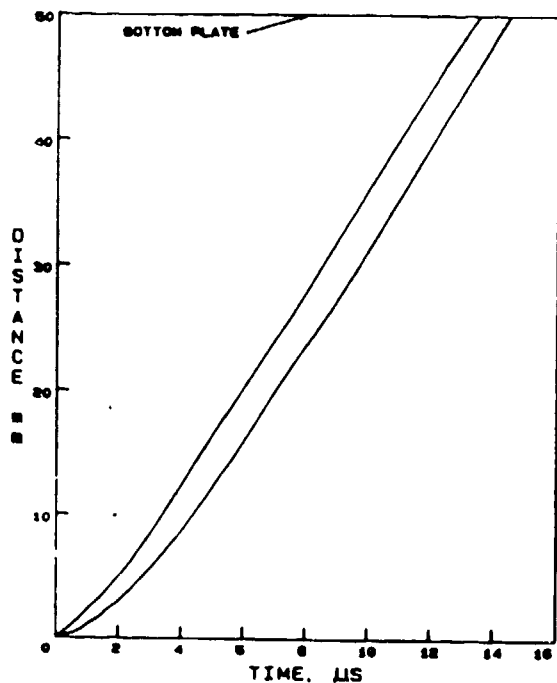

Fig. 5. Calculated driver plate position where the explosive is initially in contact with the plate (left curve) and with a 12.7-mm standoff (right curve).

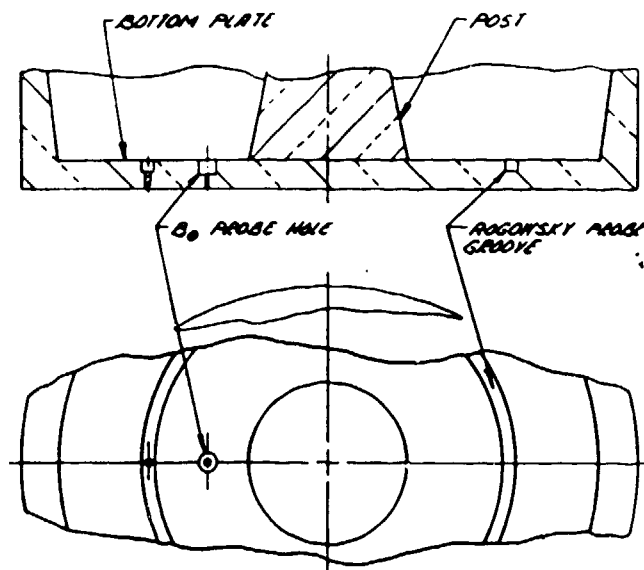

Fig. 6. Location of current and field probes in bottom plate.

Figure 7 shows traces of current vs time from first driver plate motion. The left curve taken from one of the two shots with the explosive in contact with the driver plate, shows an initial current of 1.58 MA and peak current of 24.2 MA, with a gain ratio of 15.3. The time to peak current was 12.7 μs , somewhat shorter than the 13.4 μs predicted from Fig. 5. The other curve, taken from the shot with explosive-driver plate stand off, had an initial current of 1.08 MA and a peak current of 30.8 MA, giving a current gain ratio of 28.5. Current peak occurred at 15.7 μs somewhat longer than the 14.4 μs predicted from Fig. 5. The second shot with explosive-driver plate contact gave results quite similar to that plotted on Fig. 7. The initial current was 1.42 MA and the peak current was 21 MA, thus giving a current gain ratio of 14.8. Peak current occurred at 12.8 μs , about the same as its companion shot.

Figure 7 also shows that it took much more time to achieve a significant current increase for the case with explosive-driver plate stand off. This is qualitatively consistent with the reduced acceleration of the driver plate as shown in Fig. 5. Somewhat more quantitatively, the generator inductance from Fig. 5 should be halved in about 6.5 μs for the in-contact case and in about 7.8 μs for the stand-off case. (No losses are considered, but the angles of the post and cylindrical glide surface are accounted for in the inductance calculations.) From Fig. 7, however, the current doubling times are seen to be about 6.6 μs and 9.6 μs , respectively, for the corresponding experiments. Thus, in the stand-off shot, the driver plate seems to have lost about 1.5 μs in its early motion. It is possible that forces not normally considered were important here, because of the much lower shocks imparted to the driver plate. An example could be the four screws securing this plate to the central post.

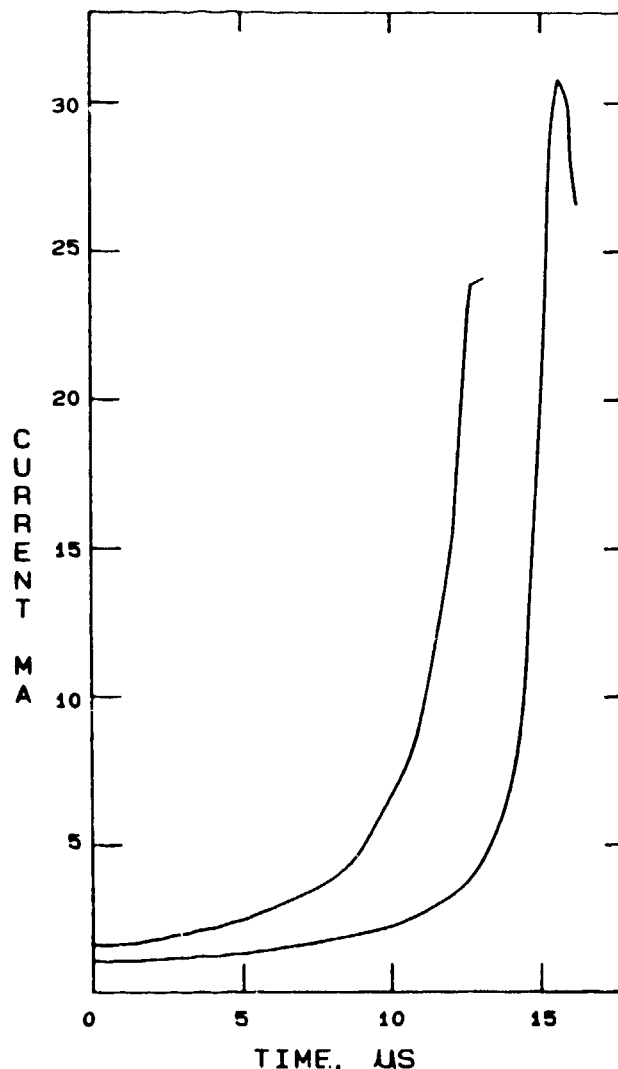

Fig. 7. Measured currents vs. time from start of driver plate motion. For the curve on the left, the explosive was in contact with the driver plate. For the curve on the right there was a 12.7-mm stand off between driver plate and explosive.

It is interesting that peak values of \dot{I} for both curves of Fig. 7 were about $3.1 \cdot 10^{13}$ amp/s, and both occurred at currents in the neighborhood of 22 MA.

One other item of interest is the different probe signals obtained beyond peak. The current signal for the left curve was obtained from a Rogowski probe, while the signal from the right curve was obtained from a B_{θ} probe. We think the left signal reflects continued flux compression inside the Rogowski loop channel after driver plate contact with the lower plate. It is likely that the Rogowski probes could be squeezed considerably before final destruction, with a consequent change in sensitivity.

A quantitative analysis of the flux losses is not possible at the present time. We have estimated losses in the post and outer cylindrical glide surfaces as only a few percent (3-5%), if the driver plate and bottom plate remained parallel. For this

situation the major flux losses arise from skin penetration into the driver and bottom plate, particularly those positions near the post, where the magnetic fields exceed a megagauss.

Fields of this magnitude are probably sufficient to melt the plates near the post. Added to this temperature rise from current heating is the substantial temperature rise from shock heating of the driver plate for the case where the explosive is in contact with the driver plate. While some current ratio gain was expected for the stand-off geometry because of the greatly reduced shock heating of the driver plate, it is difficult to account for a ratio almost twice as great as that of the in-contact case. The answer may, in part, be due more to the greater uniformity of the plate contact for the stand-off shot, as portrayed in Figs. 2b and 4b. While a major reason for the stand-off geometry was to suppress microjetting, the larger current gain ratio is an added bonus.

REFERENCES

- [1] Private Communication, 1972, from R. S. Caird, Los Alamos National Laboratory and P. J. Turchi, Air Force Weapons Laboratory, Kirtland AFB, NM (now with R and D Associates). Experiments were undertaken to study the interaction with various types of posts and driver plates. Heavier post materials, such as Ta, seemed to produce less spray at the post-driver plate contact area. No generator shots were fired. However, the generators anticipated were sometimes called "post" generators, at other times "disk" generators.
- [2] V. K. Chernyshev, M. S. Protasov, and V. A. Shevtsov, "First Discovery of the Magnetoexplosive Disk Generator," in *Ultrahigh Magnetic Fields, Physics, Techniques, Applications*, V. M. Titov and G. A. Shvetsov, Eds. pp. 23-25, Moscow "Nauka" (1984).
- [3] J. R. Asay, "Effect of Shock Wave Risetime on Material Ejection from Aluminum Surfaces," SAND77-0731 (1977), Sandia National Laboratories (Albuquerque) Report.